

MTS & MTS-B

Manual Tailstocks

The MTS and MTS-B tailstocks are designed to complement Non-lifting Indexing and NC Rotary tables when heavy and/or long work piece are machined. Quill travel is driven by handwheel. Standard center heights from 110~400mm, special sizes are available on request.



MTS & MTS-B Series / Manual Tailstock				Table model #			
Model	Center heights	Overall heights	Net weight	TRT	NCT	HC	CT-V
MTS-110	110	140	12		NCT-125		
MTS-135	135	165	13	TRT-100	NCT-170 NCT-200	HC-200	
MTS-155	155	185	14				CT-200V
MTS-170	170	200	15		NCT-250	HC-250	
MTS-190	190	220	18	TRT-170			
MTS-B-210	210	250	27		NCT-(B)-320		CT-250V
MTS-B-230	230	270	30	TRT-250		HC-320	CT-320V
MTS-B-250	250	290	33		NCT-(B)-400	HC-400	
MTS-B-255	255	295	34	TRT-320			
MTS-B-310	310	350	56		NCT-B-500	HC-500	
MTS-B-400	400	440	74		NCT-B-630		

* MTS series quill taper MT#3. * MTS-B series quill taper MT#4.

MTS

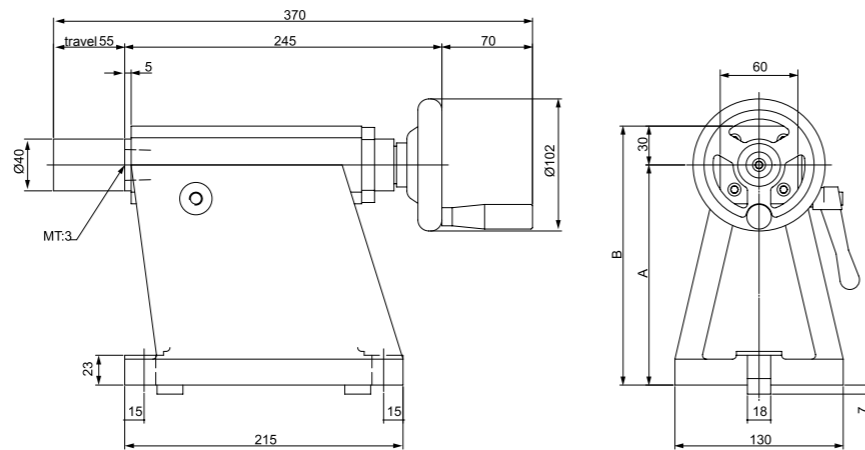

MTS-B

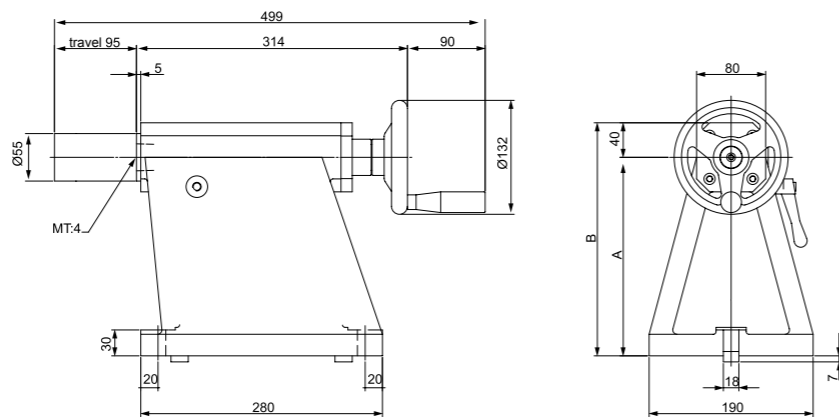

ATS & ATS-B

Auto Tailstocks

The ATS and ATS - B series tailstocks are available for either pneumatic or hydraulic operations. Standard center heights range from 110 to 400mm although alternate center heights can be produced upon request .



ATS & ATS-B Series / Automatic Tailstock				Table model #			
Model	Center heights	Overall heights	Net weight	TRT	NCT	HC	CT-V
ATS-110	110	168	18		NCT-125		
ATS-135	135	193	19	TRT-100	NCT-170 NCT-200	HC-200	
ATS-155	155	213	20				CT-200V
ATS-170	170	228	21		NCT-250	HC-250	
ATS-190	190	248	25	TRT-170			
ATS-B-210	210	267.5	34		NCT-(B)-320		CT-250V
ATS-B-230	230	287.5	37	TRT-250		HC-320	CT-320V
ATS-B-250	250	307.5	40		NCT-(B)-400	HC-400	
ATS-B-255	255	312.5	41	TRT-320			
ATS-B-310	310	367.5	63		NCT-B-500	HC-500	
ATS-B-400	400	457.5	81		NCT-B-630		

* ATS series quill taper MT#3. * ATS-B series quill taper MT#4.

ATS

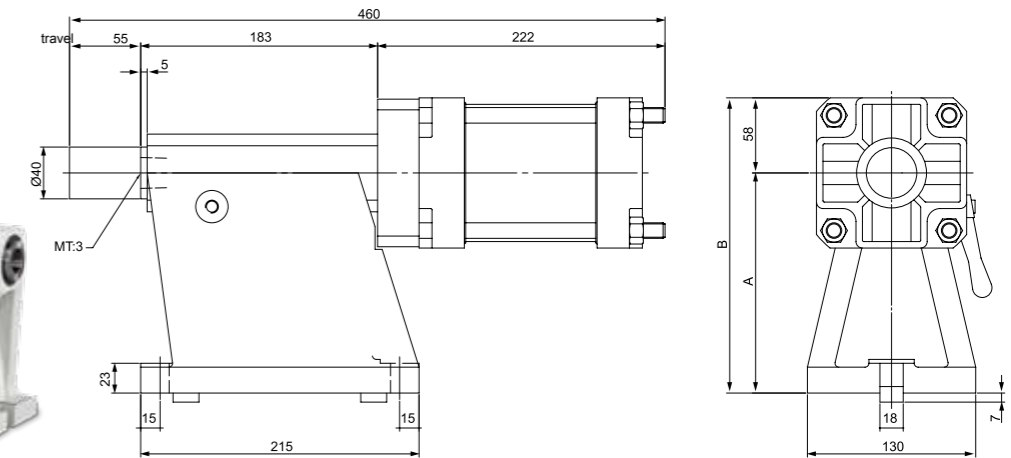

ATS-B

