

BTS

Support Tailstocks with Hydraulic Clamping

The heavy duty BTS series of tailstocks are fitted with a distortion free hydraulic brake assembly for maximum holding power. Used to support long and / or heavy piece parts or when fabricating a trunion style work holding fixture.

Operating pressure = 35 bar

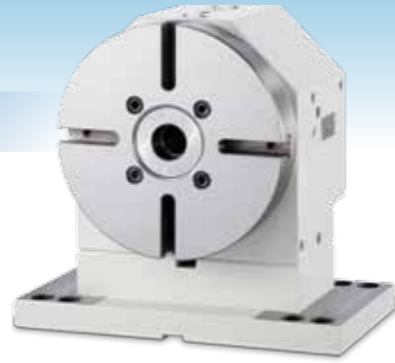

BTS Support Tailstock with Hydraulic Clamping										Table model #			
Mode	Central height	B	C	D	E	F	G	K	T	Net weight	NCT	HC	CT-V
BTS-125	110	190	195	150	40 ^{H7}	25	14 ^{H7}	70	12 ^{H7}	30	NCT-125		
BTS-170	135	221	170	125	30 ^{H7}	25	14 ^{H7}	94	12 ^{H7}	27	NCT-170	HC-200	
	135	221								27	NCT-200		
	155	241								33			CT-200V
BTS-200	155	255	200	160	30 ^{H7}	27	18 ^{H7}	100	12 ^{H7}	41			CT-200V
	170	270								47	NCT-250	HC-250	
	210	310								55			CT-250V
BTS-250	170	300	260	150	50 ^{H7}	32	18 ^{H7}	120	12 ^{H7}	79	NCT-250	HC-250	
	210	340								85	NCT-(B)-320		CT-250V
	230	360								90		HC-320	CT-320V
BTS-320	210	390	320	195	50 ^{H7}	32	18 ^{H7}	150	14 ^{H7}	116	NCT-(B)-320		
	230	390								120		HC-320	CT-320V
	250	410								122	NCT-(B)-400	HC-400	
BTS-400	250	455	410	230	60 ^{H7}	51	18 ^{H7}	140	14 ^{H7}	238	NCT-(B)-400	HC-400	
	310	515								258	NCT-B-500	HC-500	
	400	605								290	NCT-B-630		
	480	685								350	NCT-B-800		
BTS-600	400	705	610	240	75 ^{H7}	65	18 ^{H7}	200	18 ^{H7}	547	NCT-B-630		
	480	785								656	NCT-B-800		
	650	955								1378	NCT-B-1000		
BTS-800	480	890	820	350	295 ^{H7}	250	22 ^{H7}	360	22 ^{H7}	787	NCT-B-800		
	650	1060								1653	NCT-B-1000		
	750	1160								1985	NCT-B-1200		
BTS-1000	650	1160	1020	380	305 ^{H7}	260	22 ^{H7}	410	22 ^{H7}	1985	NCT-B-1000		
	750	1260								2382	NCT-B-1200		

* Most models are available with an integral Hirth coupling for an increased tangential load capacity.

BTS

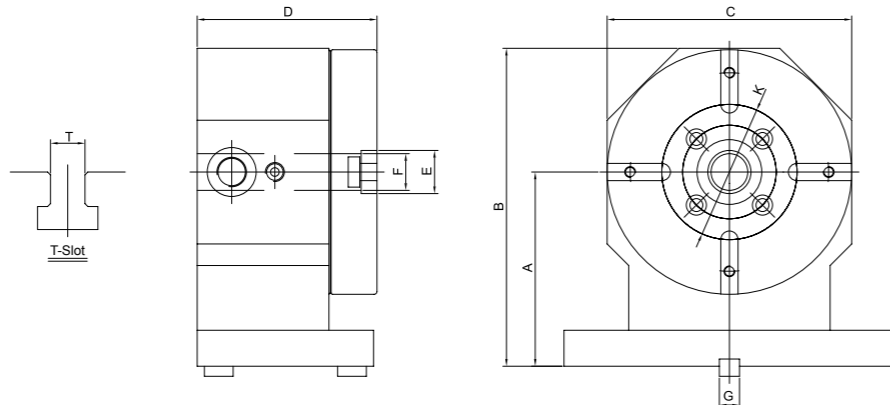

Accessories



BTS Tailstock



Fixture plate support bracket



Table: NC or Indexing

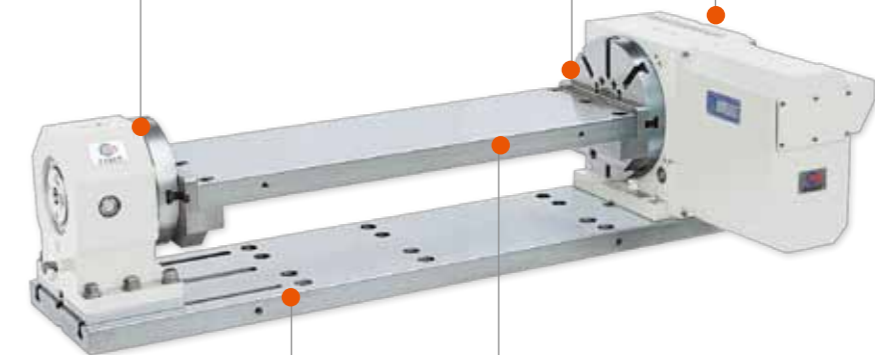

Base Plate



Fixture Plate

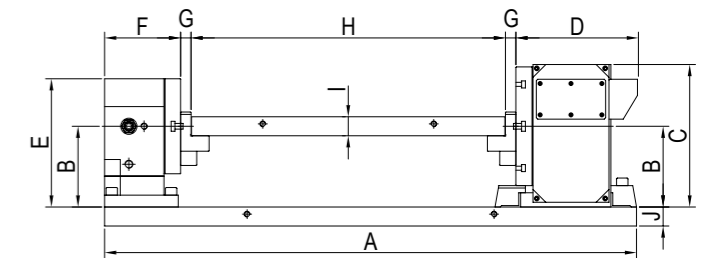
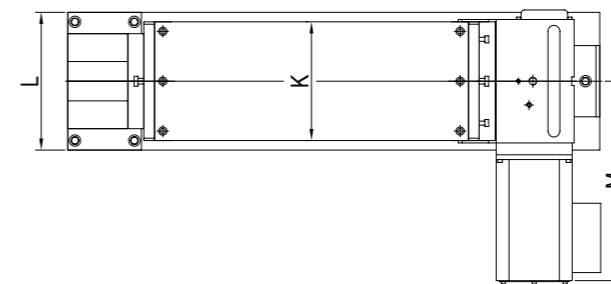

Model / Size	A*	B	C	D	E	F	G	H*	I	J	K	L*	M
NCT-125R+BTS-125	700	110	235	224	190	150	22	258	25	30	125	240	325
NCT-170R+BTS-170	800	135	275	245	220	125	22	392	30	35	170	250	350
NCT-200R+BTS-170	1000	135	273	246	220	125	22	587	40	40	200	250	355
NCT-250R+BTS-200	1120	170	300	256	270	160	22	662	40	40	250	290	420
NCT-320R+BTS-250	1200	210	385	328	340	150	25	710	50	50	320	340	410

* Details to suit the application.