

# TRT

## CNC Rotary Tilting Tables

TRT, NC controlled 2 axis tables are suitable for larger work capacities when 5 axis machining. One piece housing structure with powerful hydraulic clamping system offers a greater clamping torque and high loading capacities. Designed for easy installation and alignment.

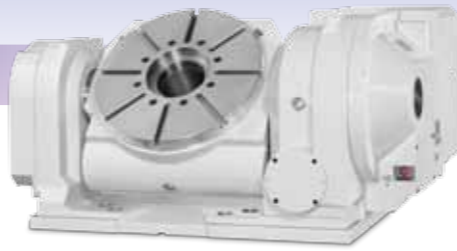

# TRT-TN

## CNC Multi Spindle Tilting Rotary Table

TRT-TN offers multi station 5 axes machining operation. This enhances the productivity for mass production. One piece frame structure offers high stability.



Model		TRT-100	TRT-170	TRT-250	TRT-320	TRT-450					
Table diameter	(mm)	Ø90	Ø170	Ø250	Ø320	Ø450					
Diameter of "Pilot" bore	(mm)	Ø55 <sup>H7</sup>	Ø75 <sup>H7</sup>	Ø50 <sup>H7</sup>	Ø60 <sup>H7</sup>	Ø170 <sup>H7</sup>					
Diameter of through hole	(mm)	Ø35	Ø50	Ø40	Ø46	Ø130					
Table height at 0°	(mm)	190	303	320	355	435					
Table height at 90° tilted	(mm)	233	330	360	420	560					
Table Center height at 90° tilted	(mm)	135	215	230	255	335					
Width of T slots	(mm)	x	12 <sup>H7</sup>	12 <sup>H7</sup>	14 <sup>H7</sup>	14 <sup>H7</sup>					
Width of alignment key in mounting base	(mm)	14 <sup>H7</sup>	18 <sup>H7</sup>	18 <sup>H7</sup>	18 <sup>H7</sup>	18 <sup>H7</sup>					
Clamp operation pressure (Hydraulic)	(bar)	5 (Pneumatic)	35	35	35	35					
Ambient temperature	(°C)	18°~40°									
Axis		Rotary	Tilting	Rotary	Tilting	Rotary	Tilting	Rotary	Tilting	Rotary	Tilting
Minimum input increment	(degree)	0.001°	0.001°	0.001°	0.001°	0.001°	0.001°	0.001°	0.001°	0.001°	0.001°
Gear ratio, Motor to Table Top		1/60	1/120	1/60	1/120	1/360	1/360	1/360	1/360	1/180	1/360
Table speed	(motor 3000 r.p.m)	50	25	50	25	8.3	8.3	8.3	8.3	16.6	8.3
	(motor 5000 r.p.m)	83.3	41.6	83.3	41.6	13.8	13.8	13.8	13.8	27.7	13.8
Servo motor (Optional)	FANUC	α2i	α2i	α2i	α8i	α8i	α8i	α8i	α8i	α12i	α12i
	MITSUBISHI	HF-75T	HF-75T	HF-75T	HF-104S	HF-104S	HF-104S	HF-104S	HF-104S	HF-204S	HF-204S
	SIEMENS	1FK7042	1FK7042	1FK7042	1FK7063	1FK7063	1FK7063	1FK7063	1FK7063	1FK7083	1FK7083
Indexing accuracy	(sec of arc)	60"	60"	20"	60"	15"	60"	15"	60"	15"	60"
Repeatability	(sec of arc)	4"	8"	4"	8"	4"	8"	4"	8"	4"	8"
Tilting range	(Horizontal = 0°)	-20°~+110°		-40°~+110°		-110°~+110°		-110°~+110°		-110°~+110°	
Clamping torque	(kgf-m)	8.5	8.5	16	16	47	47	78	78	170	170
	(N-m)	83	83	157	157	460	460	764	764	1666	1666
Permissible load (With table clamped)	F	(kgf)	350	500	900	1800	2500				
		(N)	3430	4900	8820	17640	24500				
	FxL	(kgf-m)	15	50	50	85	180				
		(N-m)	147	490	490	833	1764				
Permissible piece part and fixture weight	FxL	(kgf-m)	15	85	50	100	180				
		(N-m)	147	833	490	980	1764				
Permissible piece part and fixture weight	0°	(kg)	40	60	100	150	250				
	0~90°	(kg)	25	40	50	100	150				
Permissible work moment	WxL	(kgf-m)	3	8	16	25	30				
		(N-m)	29.4	78.4	156.8	245	294				
Net Weight	(kg)	105	180	340	500	900					
Allowable work inertia	$J = \frac{W \cdot D^2}{8}$	(kg-m <sup>2</sup> )	0.05	0.18	0.78	1.92	6.33				

### Guaranteed inspection accuracy

1	2	3	4	5	6

Model		TRT-100-T2	TRT-170-T2	TRT-250-T2			
Table diameter	(mm)	Ø115	Ø170	Ø250			
Diameter of "Pilot" bore	(mm)	Ø55 <sup>H7</sup>	Ø35 <sup>H7</sup>	Ø50 <sup>H7</sup>			
Diameter of through hole	(mm)	Ø35	Ø25	Ø40			
Table height at 0°	(mm)	190	260	320			
Table height at 90° tilted	(mm)	233	280	360			
Table Center height at 90° tilted	(mm)	135	190	230			
Width of T slots	(mm)	x	12 <sup>H7</sup>	12 <sup>H7</sup>			
Width of alignment key in mounting base	(mm)	14 <sup>H7</sup>	18 <sup>H7</sup>	18 <sup>H7</sup>			
Clamp operation pressure (Hydraulic)	(bar)	5 (Pneumatic)	35	35			
Ambient temperature	(°C)	18°~40°					
Axis		Rotary	Tilting	Rotary	Tilting	Rotary	Tilting
Minimum input increment	(degree)	0.001°	0.001°	0.001°	0.001°	0.001°	0.001°
Gear ratio, Motor to Table Top		1/60	1/120	1/60	1/120	1/360	1/360
Table speed	(motor 3000 r.p.m)	50	25	50	25	8.3	8.3
	(motor 5000 r.p.m)	83.3	41.6	83.3	41.6	13.8	13.8
Servo motor (Optional)	FANUC	α4i	α4i	α4i	α4i	α8i	α8i
	MITSUBISHI	HF-54T	HF-54T	HF-54T	HF-54T	HF-104S	HF-104S
	SIEMENS	1FK7060	1FK7060	1FK7060	1FK7060	1FK7063	1FK7063
Indexing accuracy	(sec of arc)	60"	60"	20"	60"	15"	60"
Repeatability	(sec of arc)	4"	8"	4"	8"	4"	8"
Tilting range	(Horizontal = 0°)	-20°~+110°		-40°~+110°		-110°~+110°	
Clamping torque	(kgf-m)	8.5	8.5	16	16	47	47
	(N-m)	83	83	157	157	460	460
Permissible load (With table clamped)	F	(kgf)	175 (Single table)	250 (Single table)	450 (Single table)		
		(N)	1715	2450	4410		
	FxL	(kgf-m)	15	17	50		
		(N-m)	147	167	490		
Permissible piece part and fixture weight	FxL	(kgf-m)	15	17	50		
		(N-m)	147	167	490		
Permissible piece part and fixture weight	0°	(kg)	20 (Single table)	25 (Single table)	50 (Single table)		
	0~90°	(kg)	13 (Single table)	18 (Single table)	25 (Single table)		
Permissible work moment	WxL	(kgf-m)	3	8	16		
		(N-m)	29.4	78.4	156.8		
Net Weight	(kg)	150	250	450			
Allowable work inertia	$J = \frac{W \cdot D^2}{8}$	(kg-m <sup>2</sup> )	0.05	0.18	0.78		

\* We reserve the right to make changes arising from constant product development without advance notice.

\* The list of fitting servomotor, please refer to page 61.

NO	Inspection items	TRT-100	TRT-170	TRT-250	TRT-320	TRT-450
1	Table flatness	Per overall length	0.01	0.015	0.015	0.015
2	Table run out		0.01	0.01	0.01	0.015
3	Parallelism of table top to frame bottom	Per overall length	0.02	0.02	0.02	0.02
4	Parallelism of table top to center line	Per overall length	0.02	0.02	0.02	0.02
5	Concentricity of center hole		0.01	0.01	0.01	0.01
6	Parallelism of table top to frame bottom guide blocks	Per overall length	0.02	0.02	0.02	0.02

## Layout Dimension of TRT series

TRT-100

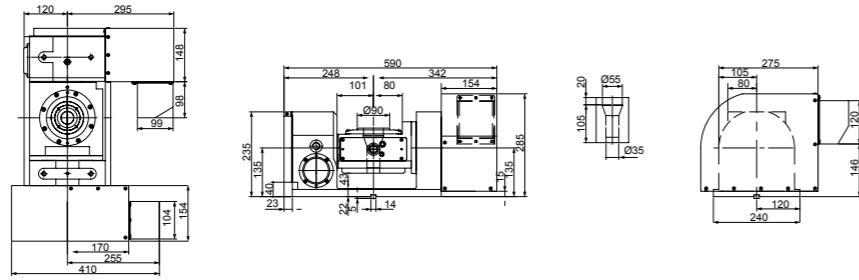

TRT-170

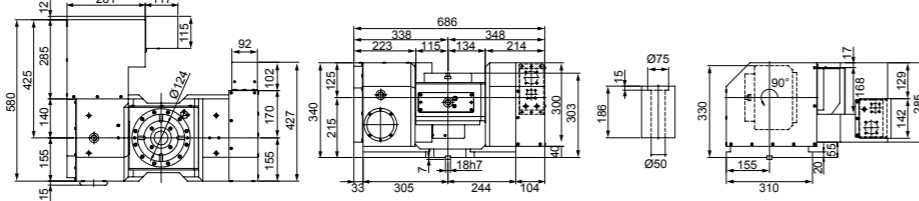

TRT-250

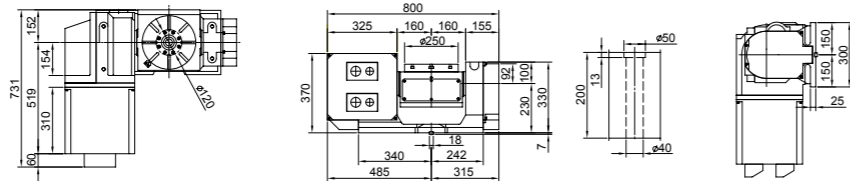

TRT-320

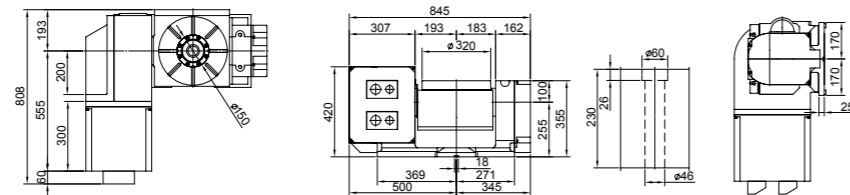

TRT-450

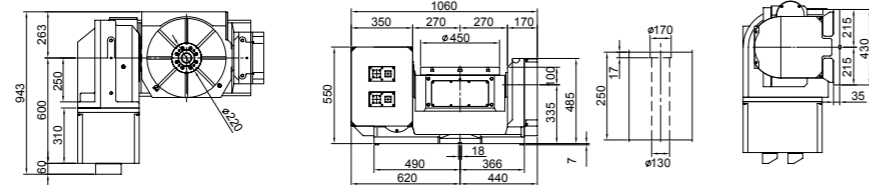

## Layout Dimension of TRT-TN

TRT-100-T2

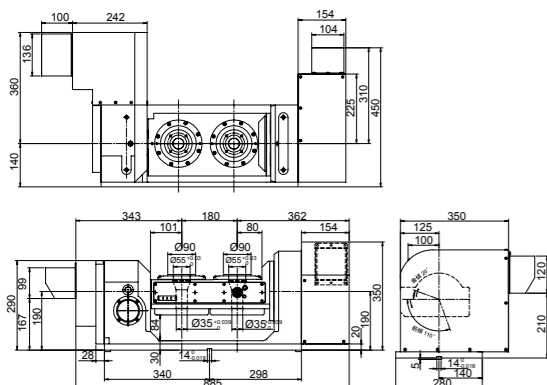

TRT-250-T2

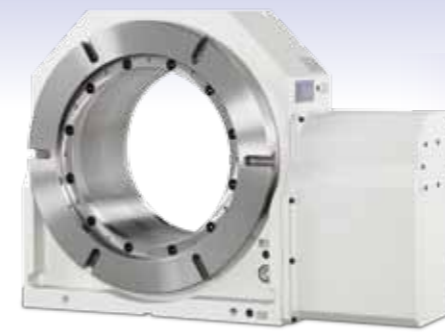
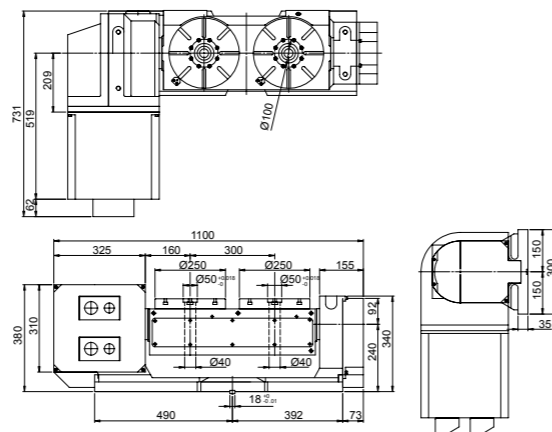

## NCT-L

### Mega Through Hole CNC Rotary Table

- \* Suitable for large workpiece machining  
Ø345mm very large through hole and table diameter  
Ø530mm is particularly good for pipeline machining.
- \* Excellent for heavy loading and high accuracy  
Rigid structure design and hydraulic clamping system.
- \* Compact design

Model		NCT-L-530R		
Table diameter	(mm)	Ø530		
Diameter of "Pilot" bore	(mm)	Ø400 <sup>H7</sup>		
Diameter of through hole	(mm)	Ø345		
Table height at 0°	(mm)	250		
Table Center height at 90° tilted	(mm)	310		
Width of T slots	(mm)	18 <sup>H7</sup>		
Width of alignment key in mounting base	(mm)	18 <sup>H7</sup>		
Clamp operation pressure (Hydraulic)	(kg/cm <sup>2</sup> )	35 bar		
Ambient temperature	(°C)	18°~40°		
Minimum input increment	(degree)	0.001°		
Gear ratio, Motor to Table Top		1/180		
Table speed	(motor 3000 r.p.m)	16.7		
Servo motor (Optional)	FANUC	α12i		
Indexing accuracy	(sec of arc)	15"		
Repeatability	(sec of arc)	4"		
Clamping torque	(kgf-m) (N-m)	428 4200		
Permissible load (With table clamped)	F		(kgf) (N)	2300 22540
	FxL		(kgf-m) (N-m)	459 4500
	FxL		(kgf-m) (N-m)	250 2450
Permissible piece part and fixture weight	0°		(kg)	1000
	90°		(kg)	500
Net Weight			(kg)	450
Allowable work inertia	$J = \frac{W \cdot D^2}{8}$		(kg-m <sup>2</sup> )	35

\* We reserve the right to make changes arising from constant product development without advance notice.

\* The list of fitting servomotor, please refer to page 61.

NCT-L-530R

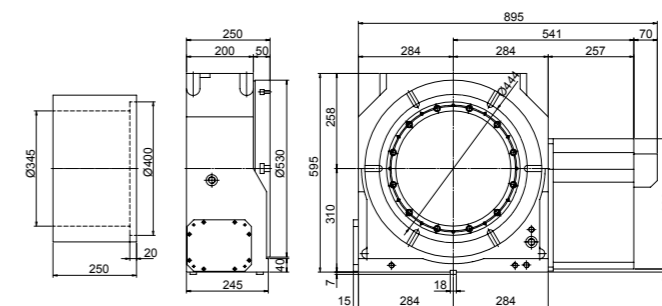

# NCT-T

## CNC Rotary Tables / Manual Tilting Axis

NCT-T NC Rotary Tables mounted onto a rugged manually adjustable base. An integral rotary table structure with a powerful clamping system fitted to tilting base with a working angle range of 0° to 100° for greater working capacity.



Model		NCT-250T	NCT-320T	NCT-400T			
Table diameter	(mm)	Ø250	Ø320	Ø400			
Diameter of "Pilot" bore	(mm)	Ø50 <sup>H7</sup>	Ø60 <sup>H7</sup>	Ø60 <sup>H7</sup>			
Diameter of through hole	(mm)	Ø40	Ø46	Ø51			
Table height at 0°	(mm)	295	335	364			
Table height at 90° tilted	(mm)	450	604	671			
Table Center height at 90° tilted	(mm)	215	265	290			
Width of T slots	(mm)	12 <sup>H7</sup>	14 <sup>H7</sup>	14 <sup>H7</sup>			
Width of alignment key in mounting base	(mm)	18 <sup>H7</sup>	18 <sup>H7</sup>	18 <sup>H7</sup>			
Clamp operation pressure (Hydraulic)	(bar)	35	35	35			
Ambient temperature	(°C)	18°~40°					
Axis		Rotary	Tilting	Rotary	Tilting	Rotary	Tilting
Minimum input increment	(degree)	0.001°	0.08°(5')	0.001°	0.01°(6')	0.001°	0.01°(6')
Gear ratio, Motor to Table Top		1/120	1/40	1/120	1/90	1/180	1/90
Table speed	(motor 3000 r.p.m)	25	X	25	X	16.6	X
	(motor 4000 r.p.m)	33.3	X	33.3	X	22.2	X
Servo motor (Optional)	FANUC	α8i	Manual	α12i	Manual	α12i	Manual
	MITSUBISHI	HF-104S	Manual	HF-204S	Manual	HF-204S	Manual
	SIEMENS	1FK7063	Manual	1FK7083	Manual	1FK7083	Manual
Indexing accuracy	(sec of arc)	15"		15"		15"	
Repeatability	(sec of arc)	4"		4"		4"	
Tilting range	(Horizontal = 0°)	0°~+100°		0°~+100°		0°~+100°	
Clamping torque	(kgf-m)	47		78		170	
	(N-m)	460		764		1666	
Permissible load (With table clamped)	F	(kgf)	1400		1700		2000
		(N)	13720		16660		19600
	FxL	(kgf-m)	50		85		180
		(N-m)	490		833		1764
	FxL	(kgf-m)	85		110		180
		(N-m)	833		1078		1764
Permissible piece part and fixture weight	0°	(kg)	250		350		500
	90°	(kg)	100		150		200
Net Weight	(kg)	250		360		450	
Allowable work inertia	$J = \frac{W \cdot D^2}{8}$	(kg-m <sup>2</sup> )	1.95		4.48		10.00

\* We reserve the right to make changes arising from constant product development without advance notice.

\* The list of fitting servomotor, please refer to page 61.

### Standard accessories

Block nuts	Hangers
☉	☉

### Optional accessories

DNS controller	Tailstock		3-jaw chuck with sub plate	Encoder	PHC
	Taper	Support			
*(p.54)	*(p.50)	*(p.52)	*(p.60)	*(p.61)	*(p.60)

### NCT-250T

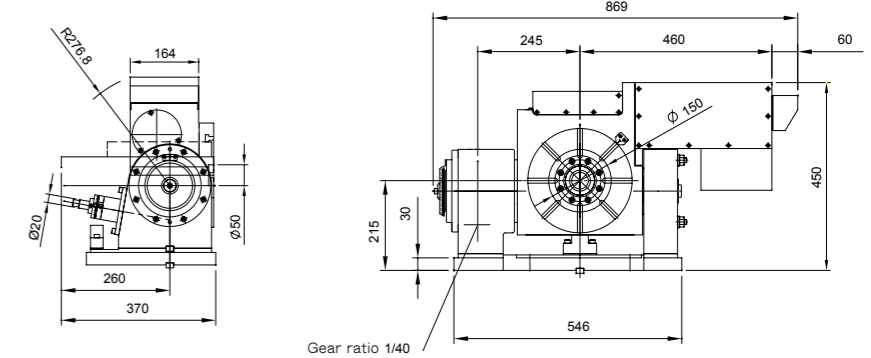

### NCT-320T

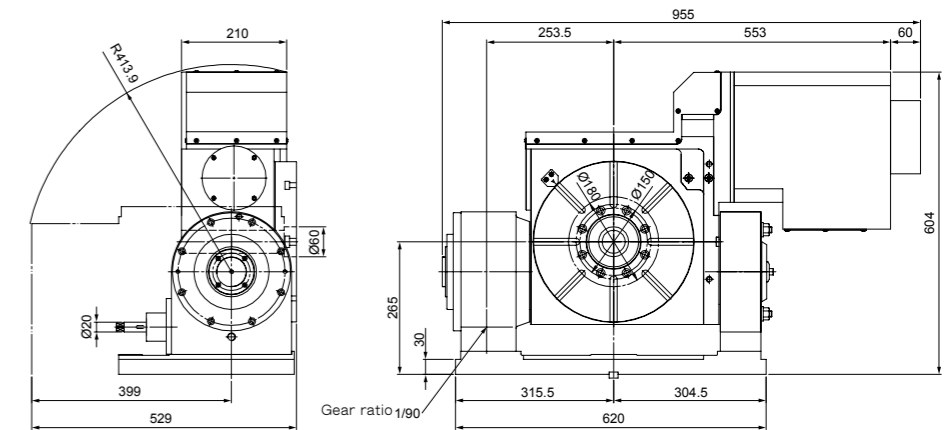

### NCT-400T

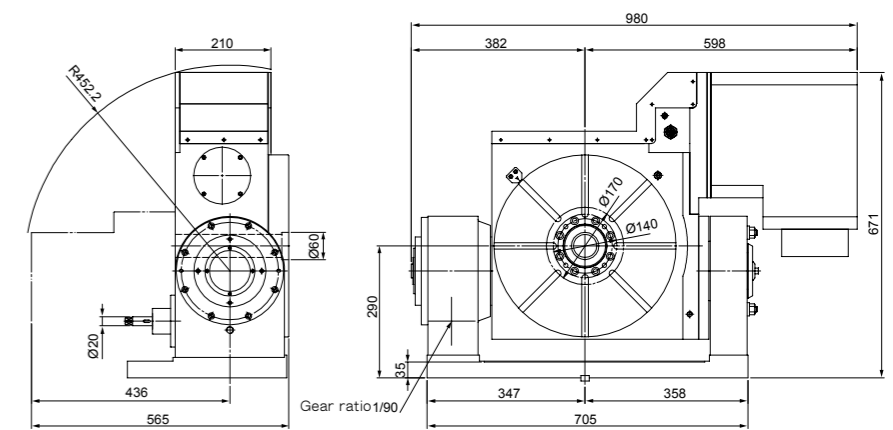

### Optional

A Heidenhain ROD-486 scale (option) can be fit for easy position degree reading.

